

MANUAL
on
CONCRETE LABORATORY

INSTRUCTION TO STUDENTS:

1. Listen carefully to the lecture given by teacher about importance of the subject, background theory, learning structure, skills to be developed, information about equipment, method of continuous assessment, tentative plan of work in laboratory and total amount of work to be done in a semester.
2. Focus on development of skills rather than theoretical or codified knowledge.
3. Read the write up of each experiment to be performed, a day in advance. Understand the purpose of experiment and its practical implications.
4. Organize the work in the group and make a record of all observations.
5. Should not hesitate to ask concerned teacher / laboratory assistants about any difficulty faced during conduct of practical.
6. Study all the questions given in the laboratory manual and write the answers to these. It should be done during practical hours if possible or afterwards, but immediately.
7. Develop habit to submit the practical, exercise continuously and progressively on the scheduled dates and should get the assessment done.
8. Develop the habit of pocket discussion / group discussion related to the experiments / exercises so that exchanges of knowledge / skills could take place.
9. Develop the habit of evolving more ideas, innovations, skills etc. those included in the scope of the manual. Refer technical magazines, proceedings of the Seminars; refer websites related to the scope of the subjects for updating knowledge and skills.
10. Be well prepared while submitting the write up of the exercise. This will develop the continuity of the studies and you will not be over loaded at the end of the term.

REPORT WRITING:

Every student is required to submit his own separate report for each test conducted. In general, the reports should be arranged in the following order:

Title : Indicates the nature of the test and the specifications number used.

Scope : Contains brief statement of the purpose and significance of the test.

Apparatus : Special equipment used for the test should be listed.

Materials : Provides the materials used or tested.

Procedure : This section should contain detail procedures adopted for the experiment.

Observations: Provide the laboratory data preferably in tabular form. Observations related to material behaviour should be included. All equations or formulas used should be clearly indicated.

Results : The results of the test should be summarized in tabular or graphical form.

Conclusion: This section should provide a brief conclusion drawn from the experiment.

Precautions: The precautions necessary for smooth conduct of this experiment is listed.

TABLE OF CONTENTS

No.	Title of experiment	Page
1	Determination of fineness of cement by dry sieving	1
2	Consistency test on cement	3
3	Determination of setting times of cement	5
4	Determination of soundness of cement	8
5	Determination of specific gravity of cement	10
6	Determination of compressive strength of cement	12
7	Sieve analysis of coarse and fine aggregates	16
8	Specific gravity and water absorption of fine aggregates	21
9	Specific gravity and water absorption of coarse aggregates	24
10	Bulking of sand	26
11	Measurement of workability of concrete by slump cone test	28
12	Measurement of workability of concrete by compaction factor test	31
13	Tests for determination of compressive strength of concrete	34
14	Tests for determination of flexural strength of concrete	38
15	Tests for determination of splitting tensile strength of concrete	42
16	Tests on bricks	45

EXPERIMENT NO. 1

DETERMINATION OF FINENESS OF CEMENT BY SIEVING

Theory: Cement is obtained by grinding various raw materials after calcination. The degree to which cement is ground to smaller and smaller particles is called fineness of cement. The fineness of cement has an important role on the rate of hydration and hence on the rate of gain of strength and also on the rate of evolution of heat. Finer cement offers a greater surface area for hydration and hence the faster development of strength although the ultimate strength is not affected. Fineness also provides more cohesiveness to concrete and avoid separation of water at the top of concrete (called bleeding). However, increase in fineness of cement increases the drying shrinkage and cracking of the concrete.

Fineness of cement is tested either by sieving or by determination of specific surface using air-permeability apparatus. The specific surface is defined as the total surface area of all the particles in cm^2 per one gram of cement. Although determination of specific surface is more accurate to judge fineness of cement, it is rarely used except for specific purpose. In contrast sieving is most commonly used method to determine fineness of cement and is quite good for field works.

Objective: Determination of fineness of cement by dry sieving.

Reference: IS 4031 (Part-1):1988.

Apparatus: IS-90 micron sieve conforming to IS: 460 (Part 1-3)-1985; Weighing balance; Gauging trowel; Brush.

Material: Ordinary Portland cement

Procedure:

1. Weigh accurately 100 g of cement to the nearest 0.01 g and place it on a standard 90 micron IS sieve.
2. Break down any air-set lumps in the cement sample with fingers.
3. Agitate the sieve by giving swirling, planetary and linear movements for a period of 10 minutes or until no more fine material passes through it.
4. Collect the residue left on the sieve, using brush if necessary, and weigh the residue.
5. Express the residue as a percentage of the quantity first placed on the sieve to the nearest 0.1 percent.
6. Repeat the whole procedures two more times each using fresh 100 g sample.

Observations:

Sl. No.	Weight of sample taken (W) (in g.)	Weight of residue (R) (in g.)	% age of residue $\frac{RR}{WW} \times 100$	Average % of residue
1.				
2.				
3.				

Result:

Percentage residue of cement sample by dry sieving is _____ percentage.

Conclusions:

The given sample of cement contains less than/ more than 10% by weight of material coarser than 90 micron sieve. Therefore it satisfies/ not satisfies the criterion as specified by IS code.

Precautions: (Discuss about the precautions to be taken while conducting this experiment)

-
-
-

Questions: (Answer the following questions.)

1. Discuss the effects of fineness on hydration of cement?
2. Enumerate the advantages and disadvantages of using finer cement.
3. What is the *correction factor* of a sieve? Explain its necessity.

EXPERIMENT NO. 2

CONSISTENCY TEST ON CEMENT

Theory: This test is conducted to calculate the amount of water to be added to the cement to get a paste of standard consistency which is defined as that consistency which will permit the Vicat plunger to penetrate to a point 5 to 7 mm from the bottom of the Vicat mould. This experiment is done with the help of Vicat apparatus (Figure 1). The time taken between adding of water to the cement and filling of mould of Vicat apparatus is called as gauging time which should be between 3 to 5 minutes.

For finding out initial setting time, final setting time, soundness of cement and compressive strength of cement, it is necessary to fix the quantity of water to be mixed in cement in each case. Since different batches of cement differ in fineness, pastes with some water content may differ in consistency when first mixed. For this reason the consistency of the paste is standardized by varying the water content until the paste has a given resistance to penetration.

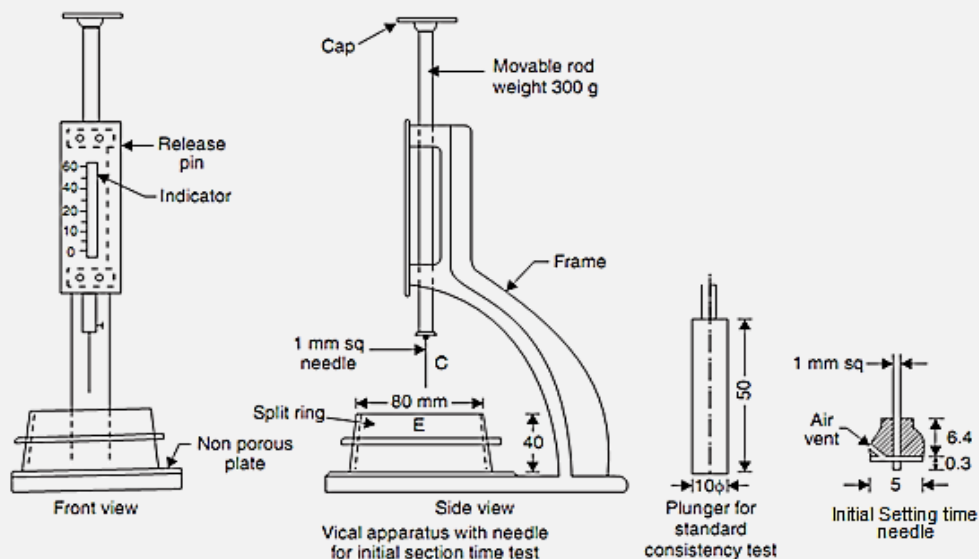

Figure 1: Vicat Apparatus

Objective: Determination of percentage of water by weight of cement required to prepare a standard acceptable (consistent) cement paste.

Reference: IS 4031 (Part-4):1988.

Apparatus: Vicat apparatus conforming to IS: 5513-1998; Weighing balance; Gauging trowel; measuring cylinder.

Material: Ordinary Portland cement; Water.

Procedure:

1. Take 400 g of cement sieved through 90 micron IS sieve and keep it on a non-porous, non-absorbent plate.
2. Add 120 ml of water (*i.e.* 30% by weight of cement) to the cement and mix thoroughly with two trowels for 3 to 5 minutes till a uniform cement paste is achieved.
3. Fill the past in mould and level with trowel. Shake or tap to remove air bubbles.
4. Place the nonporous plate and the mould under the plunger.
5. Release the plunger gently to touch the surface of paste. Record the initial reading.
6. Release the plunger quickly and allow penetrating into the paste. When the plunger comes to rest, note the final reading.
7. Repeat the procedure with fresh paste varying the water percentage until the plunger penetrates to a depth 5 to 7 mm from the bottom of the Vicat mould.

Observations:

Sl. No.	Water added (in ml)	Percentage	Initial Reading	Final Reading	Height not penetrated (in mm)

Result:

Percentage of water required to achieve normal consistency of cement paste is_____.

Precautions: (Discuss about the precautions to be taken while conducting this experiment)

-
-
-

Questions:

1. What is meant by normal consistency? Why it is determined.
2. What are the factors which affect the consistency of cement?
3. Discuss the effect of different cement grades on normal consistency.
4. What is gauging time?

EXPERIMENT NO. 3

DETERMINATION OF SETTING TIMES OF CEMENT

Theory: Cement when mixed with water forms slurry which gradually becomes lesser and lesser plastic, and finally forms a hard mass. In this process a stage is obtained when the cement paste is sufficiently rigid to with stand a definite amount of pressure. The time to reach this stage is called setting time. The setting time is divided into two parts: the initial setting time and the final setting time.

Initial set is a stage where the cement paste stiffens to such an extent that the Vicat needle is not permitted to move down through the paste within 5 ± 0.5 mm measured from the bottom of the mould. In other words, the cement paste starts losing its plasticity. The time elapsed between the moments that the water is added to the cement to the initial set is regarded as initial setting time. Any crack that may appear after initial set may not re-unite. Final setting time is the time when the paste becomes so hard that the annular attachment to the needle under standard weight only makes an impression on the hardened cement paste.

In order that the concrete may be mixed, transported and placed in position conveniently, it is necessary that the initial set of cement is not too quick. But after, it has been laid; the hardening should be rapid so that the structure can be made use of as early as possible. For an ordinary portland cement, the initial setting time should not be less than 30 minutes while the final setting time should not be more than 600 minutes.

The setting time of the cement is influenced by factors such as: percentage of water, amount of kneading the paste, temperature and humidity of the environment. As per codal provisions; this test should be conducted at temperature of $27^{\circ} \pm 2^{\circ} \text{CC}$ and 90% humidity.

Flash set and false set are two terms, which are generally encountered in relation to the setting of cements. Flash set refers to the immediate stiffening of the cement paste due to violent reaction of pure CC_3AA with water. To prevent flash set gypsum is added to the cement clinker during grinding. A phenomenon of abnormal and premature hardening of cement within a few minutes of mixing with water is termed as false set. It differs from flash set in that no appreciable heat is evolved, and remixing the cement paste without addition of water restores plasticity of the paste and the concrete sets in normal manner without a loss of strength. This happens due to dehydration of gypsum when it comes in contact with excessively hot clinkers during grinding.

Objective: Determination of initial and final setting time of cement and determine whether the values satisfy IS standards.

Reference: IS 4031 (Part-5):1988

Apparatus: Vicat apparatus conforming to IS: 5513-1998; Weighing balance; Gauging trowel; measuring cylinder; stop watch.

Material: Ordinary Portland cement; Water.

Procedure:

1. Prepare a uniform cement paste by gauging 400 g of cement with 0.85 times the water required to give a paste of standard consistency. The procedure of mixing and filling the mould is same as standard consistency.
2. Start the stopwatch or note down the time when water is added to the cement.

Determination of initial setting time:

3. Place the test block confined in the mould and resting on the non-porous plate, under the rod bearing the initial setting needle (with cross section 1 mm^2); lower the needle gently until it comes in contact with the surface of the test block and quickly release, allowing it to penetrate into the test block
4. Repeat this procedure until the needle, when brought in contact with the test block and released as described above, fails to pierce the block beyond $5.0 \pm 0.5 \text{ mm}$ measured from the bottom of the mould. Note the time.
5. The difference of time between operations (2) and (4) provides the initial setting time of cement.

Determination of final setting time:

6. Replace the initial setting needle of the Vicat apparatus by the needle with an annular attachment.
7. The cement shall be considered as finally set when, upon applying the needle gently to the surface of the test block, the needle makes an impression thereon, while the attachment fails to do so.
8. The interval of time between operation (2) and (7) provides the final setting time of cement.

Observations:

- Weight of given sample of cement is _____ g.
- The normal consistency of a given sample of cement is _____ %
- Volume of water addend (0.85 times the water required to give a paste of standard consistency) for preparation of test block _____ ml

Time in minutes :	
Height in mm fails to penetrate	

Initial setting time of cement (in min):

Final setting time (in min):

Conclusion:

The given sample of cement satisfied/ does not satisfy criterion for initial setting time.

The given sample of cement satisfied/ does not satisfy criterion for final setting time.

Precautions: (Discuss about the precautions to be taken while conducting this experiment)

-
-
-
-

Questions:

1. Describe significance of each setting time?
2. How setting of cement differs from its hardening?
3. List out the factors which affect setting times.
4. Does setting time vary with grade of cement? Explain your answer.
5. What is do you mean by false set? Why it occurs?

EXPERIMENT NO. 4

DETERMINATION OF SOUNDNESS OF CEMENT

Theory: The ability of cement to maintain a constant volume is known as soundness of the cement. It is essential that the cement concrete shall not undergo appreciable change in volume after setting. Unsoundness produces cracks, distortion and disintegration there by giving passage to water and atmospheric gases which may have injurious effects on concrete and reinforcement. Soundness of cement is ensured by limiting the quantities of free lime, magnesia and sulphates as these compounds undergo a large change in volume.

Unsoundness in cement does not come to surface for a considerable period of time. Thus this test is designed to accelerate the hydration of free lime by the application of heat thus discovering the defects in a short time. Further, to minimise the shrinkage of cement paste, the test setup is kept immersed in water bath.

This test is carried out with the help of “Le Chatelier’s apparatus” which consists of a small split cylinder of spring brass or other suitable metal of 0.5mm thickness forming a mould 30 mm internal diameter and 30mm high (Figure 2). On either side of the split mould are attached to indicators with pointed ends, the distance from these ends to the center of the cylinder being 165 mm. The mould shall be kept in good condition with the jaws not more than 50mm apart.

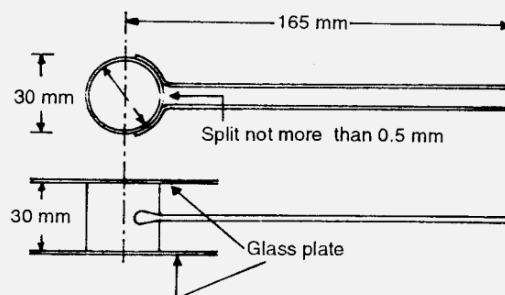

Figure 2: Le- Chatelier apparatus

Objective: Determination of soundness of cement by Le-Chatelier method.

Reference: IS 4031 (Part-3):1988.

Apparatus: Le- Chatelier apparatus conforming to IS: 5514-1969; Measuring cylinder; Gauging trowel; Balance; Water bath.

Material: Ordinary Portland cement; Water; Grease

Procedure:

1. Weigh accurately 100 g of cement to the nearest 0.15 g and add to it 0.78 times the water required to give a paste of standard consistency (i.e. $0.78 \times P$).
2. Place the lightly grease mould on a lightly grease glass sheet and fill it with cement paste, taking care to keep the edges of the mould gently together.

3. Cover the mould with another piece of lightly grease glass sheet, place a small weight on this covering glass sheet and immediately submerge the whole assembly in water at a temperature of $27 \pm 2^{\circ} \text{CC}$.
4. Keep this assembly under water for 24 hrs. After this, take the mould out of water and measure the distance between two indicators. Submerge the mould again in the water.
5. Bring the water to boiling with the mould kept submerged, and keep it boiling for 25 to 30 minutes.
6. Remove the mould from the water allow it to cool and measure the distance between the indicator points.
7. The difference between these two measurements represents the expansion of the cement.
8. Repeat the whole procedures two more times each using fresh 100 g sample.

Observations:

Samples:	
Distance between pointers before boiling (D_1) in mm	
Distance between pointers after boiling (D_2) in mm	
Expansion of the cement = $E_1 = (D_2 - D_1)$ in mm	
Average expansion of the cement in mm	

Result:

Average expansion of the cement is obtained is _____mm.

Conclusions:

Average expansion of the cement as per Le- Chatelier test is less than/ more than 10 mm. Therefore the given sample of cement is found to be sound/ unsound as per IS code.

Precautions: (Discuss about the precautions to be taken while conducting this experiment)

-
-
-

Questions:

1. What are the causes of unsoundness in cement? List out the methods to reduce unsoundness.
2. Why the cement paste is kept submerged under water during the test?
3. What is the purpose of boiling the setup?
4. What are the limiting values for maximum expansion of cement as per Le-Chatelier test for following cements: rapid hardening cement; portland puzzolana cement; high alumina cement; low heat cement; and super sulphated cement?

EXPERIMENT NO. 5

DETERMINATION OF SPECIFIC GRAVITY OF CEMENT

Theory: Specific gravity is defined as the ratio between weight of a given volume of material and weight of an equal volume of water. In case of cement, specific gravity is determined by use of a Le Chatelier's flask (Figure 3). Sometimes, a specific gravity bottle may be employed to a standard Le Chatelier's flask. To determine the specific gravity of cement, kerosene is used which does not react with cement. The specific gravity of OPC is generally around 3.15.

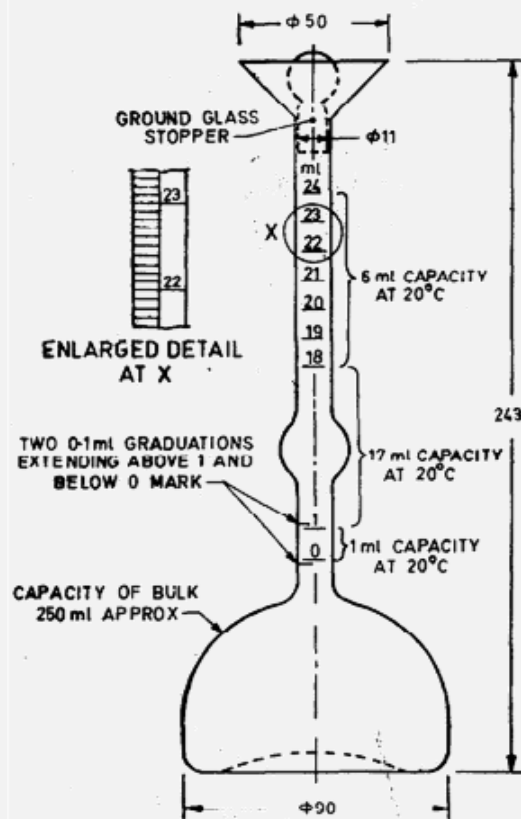

Figure 3: Le- Chatelier flask

Objective: Determination of specific gravity of cement using Le-Chatelier flask.

Reference: IS 4031 (Part-11):1988.

Apparatus: Le Chaterliers flask, weighing balance, kerosene (free from water).

Material: Ordinary Portland cement; Water; Grease

Procedure:

1. Dry the flask carefully and fill with kerosene or naphtha to a point on the stem between zero and 1 ml.

2. Record the level of the liquid in the flask as initial reading.
3. Put a weighted quantity of cement (about 60 g) into the flask so that level of kerosene rise to about 22 ml mark, care being taken to avoid splashing and to see that cement does not adhere to the sides of the above the liquid.
4. After putting all the cement to the flask, roll the flask gently in an inclined position to expel air until no further air bubble rise3s to the surface of the liquid.
5. Note down the new liquid level as final reading.

Observations:

- Weight of cement used in g. (W_1) : _____
- Initial reading of flask in ml (V_1) : _____
- Final reading of flask in ml (V_2) : _____
- Volume of cement particle ($V_2 - V_1$) : _____
- Weight of equal volume of water in g. (W_2) : _____
- Specific gravity of cement (W_1/ W_2) : _____

Result and conclusion:

Specific gravity of the given cement obtained as _____.

Precautions: (Discuss about the precautions to be taken while conducting this experiment)

-
-
-
-

Questions:

1. Why water cannot be used for determination of specific gravity of cement?
2. What are the sources of errors in this experiment?
3. If the air bubbles are not completely removed from the flask, how the results will be affected?
4. Why is it necessary to keep the temperature of test chamber constant during this experiment?

EXPERIMENT NO. 6

DETERMINATION OF COMPRESSIVE STRENGTH OF CEMENT

Theory: Among physical properties of cement, compressive strength is the most important property. When cement is used for important structures, compressive strength test is always carried out to ascertain quality of cement. Strength test is not made on plain cement due to excess shrinkage and cracking of plain cement paste. The test is therefore carried out on blocks of mortar made of cement, sand and water.

As the quality of sand from different sources varies, it is necessary to use sand of standard quality for this test. The standard sand consists of well graded sand of quartz, light grey or whitish in colour and free of silts and organic impurities. As per IS 650: 1991, standard sand is obtained from Ennore, Tamilnadu which has the following particle size distribution:

Smaller than 2 mm but greater than 1 mm	: 33.33%
Smaller than 1 mm but greater than 500 μ	: 33.33%
Smaller than 500 μ but greater than 90 μ	: 33.33%

In the mortar, cement and sand are used in the proportion of 1:3. Mortar cubes of size 70.6 mm are prepared, compacted and cured properly before testing under direct compression. The cubes are tested in compression testing machine at the end on three days, seven days and twenty eight days. For ordinary portland cement of 43 grade, the average compressive strength after 3, 7 and 28 days should not be less than 23 N/mm², 33 N/mm² and 43 N/mm² respectively.

Objective: Determination of compressive strength of cement.

Reference: IS 4031-1988 (Part-6).

Apparatus: Vibration Machine, Poking Rod, Cube Mould of 70.6 mm size conforming to IS: 10080-1982, Balance, Gauging Trowel, Watch, Graduated Glass Cylinders, etc.

Material: Ordinary portland cement (43 grade); Water; Grease, Standard sand (IS: 650-1966).

Procedure:

Preparation of cement mortar cubes:

1. Take 200gms of cement and 600 g of standard sand (*i.e.* ratio of cement to sand is 1:3) in a non-porous enamel tray and mix them with a trowel for one minute.
2. Add water quantity $\frac{P}{4} + 3.0\%$ of combined weight of cement and sand and mix the three ingredients thoroughly until the mixture is of uniform colour. ('P' is the consistency of cement). The time of mixing should be less than three minutes and not more than four minutes.

3. Immediately after mixing fill the mortar into greased cube moulds of sizes 70.6 mm.
4. Compact the mortar either by hand compaction in a standard specified manner or on the vibrating table.
5. Place the moulds in cabin at a temperature of $27^{\circ} \pm 2^{\circ}$ C for 24 hours
6. Remove the specimen from the moulds and submerge them in clean water for curing.

Testing of cement mortar cubes:

7. Take the cube out of water at the end of three days with dry cloth. Measure the dimensions of the surface in which the load is to be applied. Let them be 'L' and 'B' respectively.
8. Place the cube in compressive testing machine and apply the load uniformly at the rate of 14N/mm^2 per minute.
9. Note the load at which the cube fails. Let it be 'F'.
10. Calculate the compressive strength of the cube by using formula F/AA . Where A is the area of loaded surface (*i.e.* $L \times B$).
11. Repeat the same procedure (steps 7 to 10) for other two cubes.
12. Repeat the whole procedure (Step 7 to 11) to find the compressive strength of the cube at the end of 7 days and 28 days.

Observations:

(a) For 3 days strength:

Sl. No.	Length (L) in mm	Breadth (B) in mm	Load (F) in N	compressive strength in N/mm^2
1				
2				
3				

Average =

(b) For 7 days strength:

Sl. No.	Length (L) in mm	Breadth (B) in mm	Load (F) in N	compressive strength in N/mm ²
1				
2				
3				

Average =

(c) For 28 days strength:

Sl. No.	Length (L) in mm	Breadth (B) in mm	Load (F) in N	compressive strength in N/mm ²
1				
2				
3				

Average =

Results:

The type and grade of cement :

The compressive strength of cement at the end of

- i) 3 days : _____ . N/mm².
- ii) 7 days : _____ . N/mm².
- iii) 28 days : _____ . N/mm².

Conclusions:

Average compressive strength of cement mortar at the end of 3 days, 7 days and 28 days are _____ N/mm², _____ N/mm² and _____ N/mm², respectively. Thus the cement sample satisfies/ not satisfy the codal requirements for the given type and grade of cement.

Precautions: (Discuss about the precautions to be taken while conducting this experiment)

-
-
-
-

Questions:

1. Why strength test is not made on cubes of only cement paste?
2. What do you mean by standard sand? Why we need standard sand for present test?
3. What are the limiting values for minimum compressive strength of cement for following cements: ordinary port land cement (33; 43 and 53 grades) (at 3, 7 and 28 days); rapid hardening cement (1 and 3 days); Portland puzzolana cement (at 3, 7 and 28 days); high alumina cement at (1 and 3 days); low heat cement (at 3, 7 and 28 days); and super sulphated cement (at 3, 7 and 28 days)?
4. What will happen if the rate of application of load is more than the specified value?

EXPERIMENT NO. 7

SIEVE ANALYSIS OF COARSE AND FINE AGGREGATES

Theory:

Aggregate is the inert, inexpensive materials dispersed throughout the cement paste so as to produce a large volume of concrete. They constitute more than three quarters of volume of concrete. They provide body to the concrete, reduce shrinkage and make it durable.

The aggregates are classified in two categories; fine aggregate and coarse aggregate. The size of fine aggregates is limited to a maximum of 4.75 mm, beyond which it is known as coarse aggregates. Many a time, fine aggregates are designated as coarse sand, medium sand and fine sand. These classifications do not give any precise meaning. What the supplier terms as fine sand may be really medium or even coarse sand. To avoid this ambiguity fineness modulus could be used as a yard stick to indicate the fineness of sand and in general aggregates.

Fineness modulus for a given aggregate is obtained by sieving known weight of it in a set of standard sieves and by adding the percent weight of material retained on all the sieves and dividing the total percentage by 100. It serves the purpose of comparing one aggregate with another in respect of fineness or coarseness. For classification of fine aggregates, the following limits may be taken as guidance:

Fine sand:	Fineness modulus should lie in between 2.2 to 2.6
Medium sand:	Fineness modulus should lie in between 2.6 to 2.9
Coarse sand:	Fineness modulus should lie in between 2.9 to 3.2

Sand having a fineness modulus more than 3.2 is unsuitable for making satisfactory concrete. The coarse aggregates have fineness modulus usually more than 5.

A heap of aggregate is classified as a single sized aggregate when the bulk of aggregate passes one sieve in normal concrete series and retained on next smaller size. Such aggregates are normally expressed by the maximum size of the aggregates present in considerable amount in it. For example, a heap of 20 mm size aggregate means that the heap contains maximum 20 mm size aggregate in a substantial amount.

A graded aggregate comprises of a proportion of all sizes in a normal concrete series. When these sizes are so proportionated to provide a definite grading, it is known as well graded aggregate. Well graded aggregates are desirable for making concrete, as the space between larger particles is effectively filled by smaller particles to produce a well-packed structure. This minimizes the cement requirement.

All-in aggregates comprise a mixture of coarse aggregate and fine aggregates. Such aggregates may directly be used for low quality concreting. But in case of good quality concreting work; necessary adjustments may be made in the grading by the addition of single-sized aggregates.

IS 383:1970 specifies four grading zones for fine aggregates. These four grading zones become progressively finer from Grading Zone I to Grading Zone IV (see Table). The fine aggregates within each of these grading zones are suitable for making concrete. But, the ratio of ratio of fine to coarse aggregate reduces as the fine aggregate becomes finer from Grading Zones I to IV.

Table 1: Grading of fine aggregates

I.S. Sieve Designation	Percentage of passing by weight for grading			
	Zone-I	Zone-II	Zone-III	Zone-IV
4.75 mm	90-100	90-100	90-100	95-100
2.36 mm	60-95	75-100	85-100	95-100
1.18 mm	30-70	55-90	75-100	90-100
600 μ	15-34	35-59	60-79	80-100
300 μ	5-20	8-30	12-40	15-50
150 μ	0-10	0-10	0-10	0-15

The grading of coarse aggregate may vary through wider limits than that of fine aggregates. However, this variation does not much affect the workability, uniformity and finishing qualities of concrete mix. As per IS-383:1970 the grading limit of coarse aggregate, both for single size as well as graded should be as per the table given below.

Table 2: Grading of single-graded coarse aggregates

Sieve Size (mm)	For Single-Sized Aggregate of Nominal Size						For Graded Aggregate of Nominal Size			
	63 mm	40 mm	20 mm	16 mm	12.5 mm	10 mm	40 mm	20 mm	16 mm	12.5mm
Percentage of Passing by weight for grading										
80	100	–	–	–	–	–	100	–	–	–
63	85 to 100	100	–	–	–	–	–	–	–	–
40	0 to 30	85 to 100	100	–	–	–	95 to 100	100	–	–
20	0 to 5	0 to 20	85 to 100	100	–	–	30 to 70	95 to 100	100	100
16	–	–	–	85 to 100	100	–	–	–	90 to 100	–
12.5	–	–	–	–	85 to 100	100	–	–	–	90 to 100
10	0 to 5	0 to 5	0 to 20	0 to 30	0 to 45	85 to 100	10 to 35	25 to 55	30 to 70	40 to 85
4.75	–	–	0 to 5	0 to 5	0 to 10	0 to 20	0 to 5	0 to 10	0 to 10	0 to 10
2.36	–	–	–	–	–	0 to 5	–	–	–	–

Objective: To determine fineness modulus and grade of fine and coarse aggregate.

Reference: IS: 383-1970.

Apparatus: Set of sieves*; Balance; Gauging Trowel; Watch.

- a) * For fine aggregates: 4.75 mm, 2.36 mm, 1.18 mm, 600 micron, 300 micron & 150 micron, pan.
- b) * For coarse aggregates: 80mm, 40mm, 20mm, 10mm, 4.75mm, pan.

- Material:**
- a) Fine aggregates (1 Kg)
 - b) Coarse aggregates (5 Kg)

Procedure:

1. Take the aggregate from the sample by quartering.
2. Sieve the aggregate using the appropriate sieves.
3. Record the weight of aggregate retained on each sieve.
4. Calculate the cumulative weight of aggregate retained on each sieve.
5. Calculate the cumulative percentage of aggregate retained.
6. Add the cumulative weight of aggregate and calculate the fineness modulus using formula:

a. Fineness modulus for fine aggregates $= \frac{\sum CC}{100}$

b. Fineness modulus for coarse aggregates $= \frac{\sum CC}{100} + 5$

Where, C denotes the cumulative percentage of mass retained in a sieve.

7. Determine the grade of aggregates from the Table 1 and the Table 2.
8. Plot the gradation curves, in a semi-log graph, between percentage of aggregates passed and size of sieve both for a) Fine aggregate and b) For coarse aggregate.

(Note: A typical grading curve for fine aggregates looks like Figure 4. A similar grading curve will be observed for coarse aggregates.)

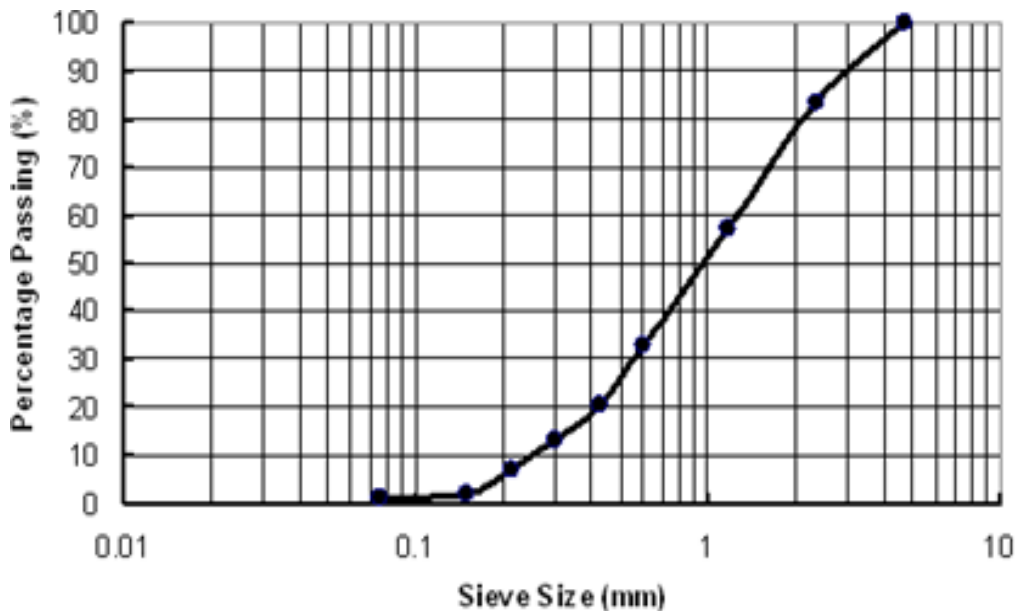

Figure 4: A typical gradation curve for fine aggregates

Observations:

(a) For fine aggregates:

Weight of fine aggregate taken (W_f): _____ Kgs					
Sl. No.	Sieve size	Weight retained (in kg)	% age retained $\frac{C_3}{WW_{ff}} \times 100$	Cumulative %age retained	Percentage passed (100 - C_5)
C_1	C_2	C_3	C_4	C_5	C_6
1	4.75 mm				
2	2.36 mm				
3	1.18 mm				
4	600 micron				
5	300 micron				
6	150 micron				
7	Pan			-	-
Sum of cumulative percentage retained (excluding pan) $\sum C_3 =$					-
Fineness Modulus $\frac{\sum C_5}{100} =$					-
Zone to which the fine aggregate belongs:					

(b) For coarse aggregates:

Weight of coarse aggregate taken (W_c): _____ Kgs					
Sl. No.	Sieve size	Weight retained (in kg)	% age retained $\frac{C_3}{WW_{cc}} \times 100$	Cumulative %age retained	Percentage passed (100 - C_5)
C_1	C_2	C_3	C_4	C_5	C_6
1	80 mm				
2	40 mm				
3	20 mm				
4	10 mm				
5	4.75 mm				
6	Pan			-	-
Sum of cumulative percentage retained (excluding pan) $\sum C_3 =$					-
Fineness Modulus $\frac{\sum C_5}{100} + 5 =$					-
Grade to which the coarse aggregate belongs:					

Results and discussions:

The fineness modulus of given samples are:

- a) For fine aggregates :_____.
- b) For coarse aggregates :_____.

The grading to which the given samples belong are:

- a) For fine aggregates :_____.
- b) For coarse aggregates :_____.

Precautions: (Discuss about the precautions to be taken while conducting this experiment)

-
-
-
-

Questions:

1. What are a) fine aggregate, b) coarse aggregate, and c) all-in aggregate?
2. What is the significance of measuring fineness modulus of aggregates?
3. What is a well graded aggregate? How grading of aggregates can be controlled?
4. What is the use of gradation curve?
5. Why well graded aggregate is most suitable for concreting purpose?

EXPERIMENT NO. 8

SPECIFIC GRAVITY AND WATER ABSORPTION OF FINE AGGREGATES

Theory:

Specific gravity of an aggregate is defined as the ratio of the mass of solid in a given volume of sample to the mass of equal volume of water at 4⁰⁰ CC. However, all rocks contain some small amount of void and the apparent specific gravity includes this voids. The specific gravity of aggregates is an indirect measure of material's density and its quality. A low specific gravity may indicate high porosity and therefore poor durability and low strength.

Some of the pores contained by aggregates are permeable while others are impermeable. Accordingly, two types of specific gravities are defined absolute specific gravity and apparent specific gravity. If both the permeable and impermeable voids are excluded to determine the true volume of solids, the specific gravity is called true or absolute specific gravity of the aggregate. But true specific gravity has not much of practical use as volume of impermeable internal pores is too difficult to determine.

In contrast, for the determination of apparent specific gravity the impermeable internal pore is added to the effective volume of the aggregates (does not include the permeable pores). Mathematically:

$$\text{Apparent Specific Gravity} = \frac{\text{mass of aggregate}}{\text{mass of water occupying the volume equal to that of solids of aggregate excluding permeable pores}}$$

The apparent specific gravity is realistic one to use for concrete mix proportioning. The apparent specific gravity of most rocks lie between 2.6 to 2.7. Apparent specific gravity can be determined on the basis of surface dry condition (SSD) or oven dry condition (OD), according to the moisture condition of the aggregate.

In saturated surface dry (SSD) situation, the pores of the aggregate are fully filled with water and the surface is dry. This condition can be obtained by immersing coarse aggregate in water for 24 h followed by drying of the surface with a wet cloth. When the aggregate is under the SSD condition, it will neither absorb water nor give out water during the mixing process. Hence, it is a balanced condition and is used as the standard index for concrete mix design.

In contrast, the oven dry condition is obtained by keeping the aggregate in an oven at a temperature of 110^o CC for 24 hrs. Due to heating, all the water from internal permeable pores gets evaporated and hence it reaches a constant weight. When the aggregate is under OD condition, it will absorb water during the concrete mixing process until the internal pores are fully filled with water.

Similarly, water absorption is also provides an idea about strength of aggregate. Aggregates having more water absorption are more porous in nature and generally considered unsuitable. Usually, water absorption of coarse aggregate is about 0.5% by weight whereas water absorption of fine aggregate is about 2.0% by weight. Moreover, water absorption values are used to calculate the change in the weight of the aggregate while proportioning and mixing of concrete. Extra water is added to cater the need of water absorption.

Objective: To determine specific gravity and water absorption of fine aggregate.

Reference: IS: 2386 (Part-3)-1963.

Apparatus: Pycnometer, 1000-ml measuring cylinder, thermostatically controlled oven, taping rod, filter papers and funnel.

Material: Fine aggregates (500 g)

Procedure:

1. Place 500 g of fine aggregate in a tray and cover it with distilled water at a temperature of 22 to 32°C. Remove air entrapped in or bubbles on the surface of the aggregate by gentle agitation with a rod. Keep the sample immersed under water for 24 Hrs.
2. Carefully drain the water from the sample, by decantation through a filter paper. Air dry the aggregate and solid matter retained on the filter paper, to remove the surface moisture. When the material just attains a “free-running” condition, weight the saturated and surface-dry sample (A).
3. Place the aggregate in the pycnometer and fill the remaining space by distilled water. Eliminate entrapped air by rotating the pycnometer on its side, covering the hole in the apex of the cone with a finger. Weight the pycnometer with this condition (B).
4. Empty the contents of the pycnometer into a tray. Ensure that all the aggregate is transferred. Refill the pycnometer with distilled water to the same level as before and measure the weight at this condition (C).
5. Carefully drain the water from the sample, by decantation through a filter paper. Oven-dry the aggregate in the tray at a temperature of 100 to 110°C for 24 hrs. During this period, stir the specimen occasionally to facilitate proper drying. Cool the aggregates calculate its weight (D).
6. Calculate the specific gravity, apparent specific gravity and the water absorption as follows:

$$\text{Specific gravity} = \{DD/[AA - (BB - CC)]\} \quad (1)$$

$$\text{Apparent Specific gravity} = \{DD/[DD - (BB - CC)]\} \quad (2)$$

$$\text{Water absorption (in \%)} = 100 \times [(AA - DD)/DD] \quad (3)$$

Where, A = Weight in g of saturated surface-dry sample

B = Weight in g of pycnometer containing sample and filled with distilled water

C = Weight in g of pycnometer filled with distilled water only

D = Weight in g of oven dried sample only.

Observations:

Weight in g of saturated surface-dry sample (A)	
Weight in g of pycnometer containing sample and filled with distilled water (B)	
Weight in g of pycnometer filled with distilled water only (C)	
Weight of oven dried- sample only (D)	
Specific gravity = $\{DD/[AA - (BB - CC)]\}$	
Apparent Specific gravity = $\{DD/[DD - (BB - CC)]\}$	
Water absorption (in %) = $100 \times [(AA - DD)/DD]$	

Results and discussions:

Following results are obtained for the provided fine aggregate specimen:

- a) Specific gravity : _____.
- b) Apparent specific gravity : _____.
- c) Water absorption : _____%.

Precautions: (Discuss about the precautions to be taken while conducting this experiment)

-
-
-
-

Questions:

1. What is the purpose of conducting water absorption test?
2. What are the limitations in determination of specific gravity using pycnometer?
3. Define unit weight, bulk density?
4. Provide proofs of equations 1, 2 and 3.

EXPERIMENT NO. 9

SPECIFIC GRAVITY AND WATER ABSORPTION OF COARSE AGGREGATES

Theory: For design of concrete mix, information about the specific gravity and water absorption of the coarse aggregates are required. Specific gravity of aggregate provides valuable information on its quality and properties. If the specific gravity is above or below than the value normally assigned to a particular type of aggregate; it may indicate that shape and grading of aggregate has altered. It is also important in determination of moisture content and in many concrete mix design calculations. It is also required for the calculation of volume yield of concrete.

Objective: To determine specific gravity and water absorption of coarse aggregate.

Reference: IS: 2386 (Part-3)-1963.

Apparatus: Balance of capacity 5kg weight, box wire basket 200mm in diameter, water container for immersing the wire basket, absorbent cloth for surface drying of the sample and thermos static drying oven.

Material: coarse aggregates (5 Kg),

Procedure:

1. A sample of not less than 2 Kg of the aggregate shall be thoroughly washed to remove finer particles and dust, drained and then placed in the wire basket and immersed in distilled water at a temperature between 22°C to 32°C with a cover of at least 5 cm of water above the top of the basket.
2. Immediately after immersion the entrapped air shall be removed from the sample by lifting the basket containing it 25 mm above the base of the tank and allowing it to drop 25 times at the rate of about one drop per second.
3. The basket and aggregate shall remain completely immersed during the operation and for a period of $24 \pm 1/2$ hours afterwards.
4. The basket and the sample shall then be jolted and weighed in water at a temperature of 22°C to 32°C (weight A).
5. The basket and the aggregate shall then be removed from the water and allowed to drain for a few minutes, after which the, aggregate shall be gently emptied from the basket on to one of the dry clothes, and the empty basket shall be returned to the water and weighed in water (weight B).
6. The aggregate placed on the dry cloth shall be gently surface dried with the cloth, transferring it to the second dry cloth when the first will remove no further moisture. The aggregate shall then be weighed (weight C).
7. The aggregate shall then be placed in the oven in the shallow tray, at a temperature of 100 to 110°C and maintained at this temperature for $24 \pm 1/2$ hours. It shall then be removed from the oven, cooled in the airtight container and weighed (weight D).

8. The specific gravity, apparent specific gravity and water absorption shall be calculated as.

$$\text{Specific gravity} = \{DD/[CC - (AA - BB)]\} \quad (1)$$

$$\text{Apparent Specific gravity} = \frac{D}{D - (AA - BB)} \quad (2)$$

$$\text{Water absorption (in \%)} = 100 \times [(CC - DD)/DD] \quad (3)$$

Where,

A = Weight in g of aggregate and basket in water

B = Weight in g of empty basket in water

C = Weight in g of the saturated surface - dry aggregate in air

D = Weight in g of oven dried aggregate in air.

Observations:

Weight of aggregate and basket in water (A)	
Weight of empty basket in water (B)	
Weight of the saturated surface - dry aggregate in air (C)	
Weight of oven dried aggregate in air (D)	
Specific gravity = $[DD/(CC - AA + BB)]$	
Apparent Specific gravity = $[DD/(CC - DD)]$	
Water absorption (in %) = $100 \times [(CC - DD)/DD]$	

Results and discussions:

Following results are obtained for the provided coarse aggregate specimen:

- a) Specific gravity : _____.
- b) Apparent specific gravity : _____.
- c) Water absorption : _____%.

Precautions: (Discuss about the precautions to be taken while conducting this experiment)

-
-
-

Questions:

1. What is the relationship between specific gravity of aggregate and the strength?
2. What are the other methods available for determination of specific gravity and water absorption of coarse aggregate?

EXPERIMENT NO. 10

BULKING OF SAND

Theory: Increase in volume of sand due to presence of moisture is known as bulking of sand. Bulking is due to the formation of thin film of water around the sand grains and the interlocking of air in between the sand grains and the film of water. When more water is added sand particles get submerged and volume again becomes equal to dry volume of sand.

Due to the bulking, fine aggregate shows completely unrealistic volume. Therefore, it is absolutely necessary that consideration must be given to the effect of bulking in proportioning the concrete by volume. If cognisance is not given to the effect of bulking, in case of volume batching, the resulting concrete is likely to be under-sanded and harsh. It will also affect the yield of concrete for given cement content.

To compensate the bulking effect extra sand is added in the concrete so that the ratio of coarse to fine aggregates will not change from the specified value. Maximum increase in volume may be 20 % to 40 % when moisture content is 5 % to 10 % by weight. Fine sands show greater percentage of bulking than coarse sands with equal percentage of moisture.

Objective: To ascertain the bulking phenomena of given sample of sand.

Reference: IS: 2386 (Part-3)-1963.

Apparatus: Beaker, 1000ml measuring jar, brush, scale, mixing tray.

Material: Fine aggregate, water.

Procedure:

1. Put sufficient quantity of dry sand into the beaker until it is about one-thirds full.
2. Level off the top of the sand and measure the height (H_1) by pushing a steel rule vertically down through the sand at the middle to the bottom. Measure weight of the sand.
3. Add 2% of water; mix it thoroughly in the container. Smooth and level the top surface measure the height (H_2) of soil. Find the height percentage increment.
4. Repeat the same procedure with increasing amount of water by 2% until percentage increment of sand height is reduced and attends original level.
5. Plot a graph of percentage increment of sand height against percentage of water.

(Note: A typical bulking of sand graph looks like Figure 5)

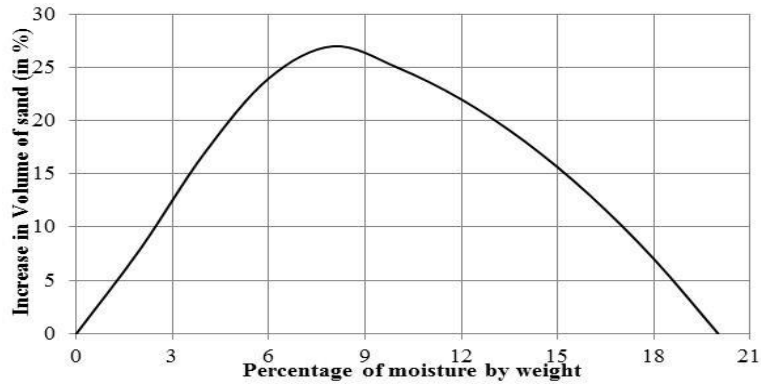

Figure 5: A typical curve showing bulking of sand

Observations:

Initial Height of sand in the Jar (H_1) : _____ mm

Weight of fine aggregate : _____ g

Sl. No.	% of Water	Volume of water (in ml)	Height of sand (H_2)	page bulking = $\frac{H_2 - H_1}{H_1} \times 111111$

Results and discussions:

From the tabulated results and the plotted graph is is observed that, the given sand specimen under goes maximum bulking at _____% of moisture contain. Maximum percentage of bulking is _____.

Precautions: (Discuss about the precautions to be taken while conducting this experiment)

-
-
-

Questions:

1. What is meant by bulking of sand? Why it happens?
2. What is the significance of bulking of sand experiment?
3. Define bulking factor?
4. What is the effect of moisture on bulking?

EXPERIMENT NO. 11
MEASUREMENT OF WORKABILITY OF CONCRETE
BY SLUMP CONE TEST

Theory:

A concrete is said to be workable if it can be easily mixed, placed, compacted and finished. A workable concrete should not show any segregation or bleeding. Segregation is said to occur when coarse aggregate tries to separate out from the finer material and a concentration of coarse aggregate at one place occurs. This results in large voids, less durability and strength. Bleeding of concrete is said to occur when excess water comes up at the surface of concrete. This causes small pores through the mass of concrete and is undesirable.

Unsupported fresh concrete flows to the sides and a sinking in height takes place. This vertical settlement is known as slump. The slump is a measure indicating the consistency or workability of cement concrete. It gives an idea of water content needed for concrete to be used for different works. To measure the slump value, the test fresh concrete is filled into a mould of specified shape and dimensions, and the settlement or slump is measured when supporting mould is removed. The slump increases as water-content is increased. For different works different slump values have been recommended. The following table indicates the relationship between degree of workability and slump value.

Degree of workability	Very Low	Low	Medium	High
Slump value (in mm)	0-25	25-50	50-100	100-175

Slump test is adopted in the laboratory or during the progress of the work in the field for determining consistency of concrete where nominal max., size of aggregates does not exceed 40 mm. The pattern of slump indicates the characteristics of concrete in addition to the slump value. If the concrete slumps evenly it is called true slump. If one half of the cone slides down, it is called shear slump. In case of a shear slump, the slump value is measured as the difference in height between the height of the mould and the average value of the subsidence. Shear slump also indicates that the concrete is non-cohesive and shows the characteristic of segregation. Any slump specimen, which collapses or shears off laterally gives incorrect results and at this juncture the test is repeated only true slump should be measured.

Although, slump test is popular due to the simplicity of apparatus used and simple procedure, unfortunately, the simplicity is also often allows a wide variability and many time it could not provide true guide to workability. For example, a harsh mix cannot be said to have same workability as one with a large proportion of sand even though they may have the same slump.

The slump cone experiment is conducted in an apparatus called slump cone (Figure 6). This apparatus essentially consists of a metallic mould in the form of a frustum of a cone having the internal dimensions as under: Bottom diameter: 20 cm, Top diameter: 10 cm, Height: 30 cm and the thickness of the metallic sheet for the mould should not be thinner than 1.6 mm.

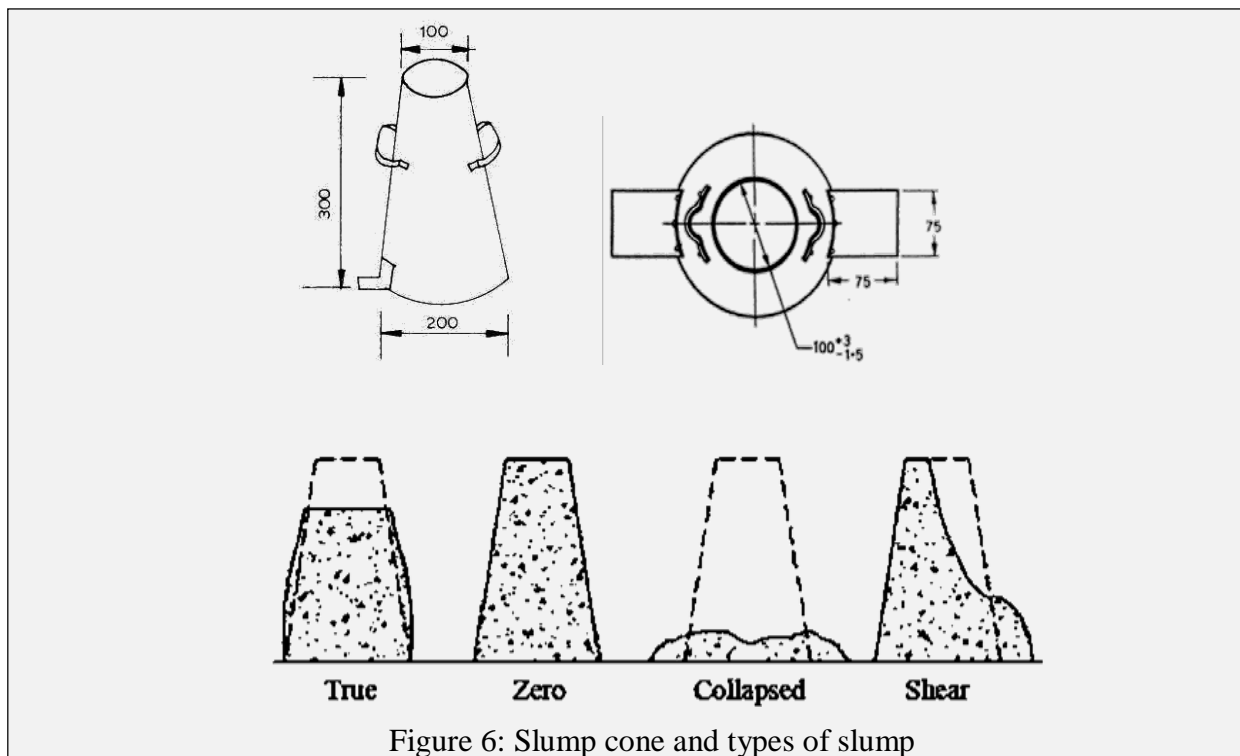

Figure 6: Slump cone and types of slump

Objective: To determine the workability of freshly mixed concrete by the use of slump test.

Reference: IS: 7320-1974, IS: 1199-1959, SP: 23-1982.

Apparatus: Slump cone, tamping rod, metallic sheet, weighing machine and scale.

Material: Cement, sand, aggregate and water

Procedure:

1. Clean the internal surface of the mould thoroughly and place it on a smooth horizontal, rigid and non-absorbent surface, such as of a metal plate.
2. Consider a W/C ratio of 0.5 to 0.6 and design mix of proportion about 1:2:4 (it is presumed that a mix is designed already for the test). Weigh the quantity of cement, sand, aggregate and water correctly. Mix thoroughly. Use this freshly prepared concrete for the test.
3. Fill the mould to about one fourth of its height with concrete. While filling, hold the mould firmly in position
4. Tamp the layer with the round end of the tamping rod with 25 strokes disturbing the strokes uniformly over the cross section.
5. Fill the mould further in 3 layers each time by 1/4th height and tamping evenly each layer as above. After completion of rodding of the topmost layer strike of the concrete with a trowel or tamping bar, level with the top of mould.
6. Lift the mould vertically slowly and remove it.
7. The concrete will subside. Measure the height of the specimen of concrete after subsidence.

8. The slump of concrete is the subsidence, i.e. difference in original height and height up to the topmost point of the subsided concrete in millimetres.

Observations:

W/C ratio	
Slump Value	

Result:

The slump of concrete is: _____mm.

Conclusions:

The slump value indicates that the concrete has Very low/ Low/ Medium/ High degree of workability.

Precautions: (Discuss about the precautions to be taken while conducting this experiment)

-
-
-

Questions:

1. What is meaning of consistency in concrete?
2. What is slump of concrete?
3. What is the significance of shear slump?
4. What is segregation?

EXPERIMENT NO. 12
MEASUREMENT OF WORKABILITY OF CONCRETE
BY COMPACTION FACTOR TEST

Theory:

This test is adopted to determine workability of concrete where nominal size of aggregate does not exceed 40 mm. It is based on the definition, that workability is that property of concrete, which determines the amount of work required to produce full compaction. The test consists essentially of applying a standard amount of work to standard quantity of concrete and measuring the resulting compaction. The compaction factor is defined as the ratio of the weight of partially compacted concrete to the weight of fully compacted concrete. It shall be stated to the nearest second decimal place. The relationship between degree of workability and compaction factor are:

Degree of workability	Very Low	Low	Medium	High
Compaction Factor	0.75- 0.80	0.80- 0.85	0.85- 0.92	>0.92

Compaction factor test is more sensitive and precise than slump test and is particularly useful for concrete mixes of very low workability. Such concrete may show zero to very low slump value. Also, compaction factor (C.F.) test is able to indicate small variations in workability over a wide range. Compaction factor test proves the fact that with increase in the size of coarse aggregate the workability will decrease. However, compaction factor test has certain limitations. When maximum size of aggregate is large as compare with mean particle size; the drop into bottom container will produce segregation and give unreliable comparison with other mixes of smaller maximum aggregate sizes. Moreover, the method of introducing concrete into mould bears no relationship to any of the more common methods of placing and compacting high concrete.

Compaction factor test apparatus consists of two conical hoppers, A and B, mounted vertically above a cylindrical mould C. The upper hopper A has internal dimensions as: top diameter 250 mm; bottom diameter 125 mm and height 225 mm. The lower hopper B has internal dimensions as: top diameter 225 mm; bottom diameter 125 mm and height 225 mm. The cylinder has internal dimensions as: 150 mm diameter and 300 mm height. The distances between bottom of upper hopper and top of lower hopper, and bottom of lower hopper and top of cylinder are 200 mm in each case. The lower ends of the hoppers are fitted with quick release flap doors. The hoppers and cylinders are rigid in construction and rigidly mounted on a frame. These hoppers and cylinder are rigid easily detachable from the frame. Figure 7 shows the diagram of a compaction factor test apparatus.

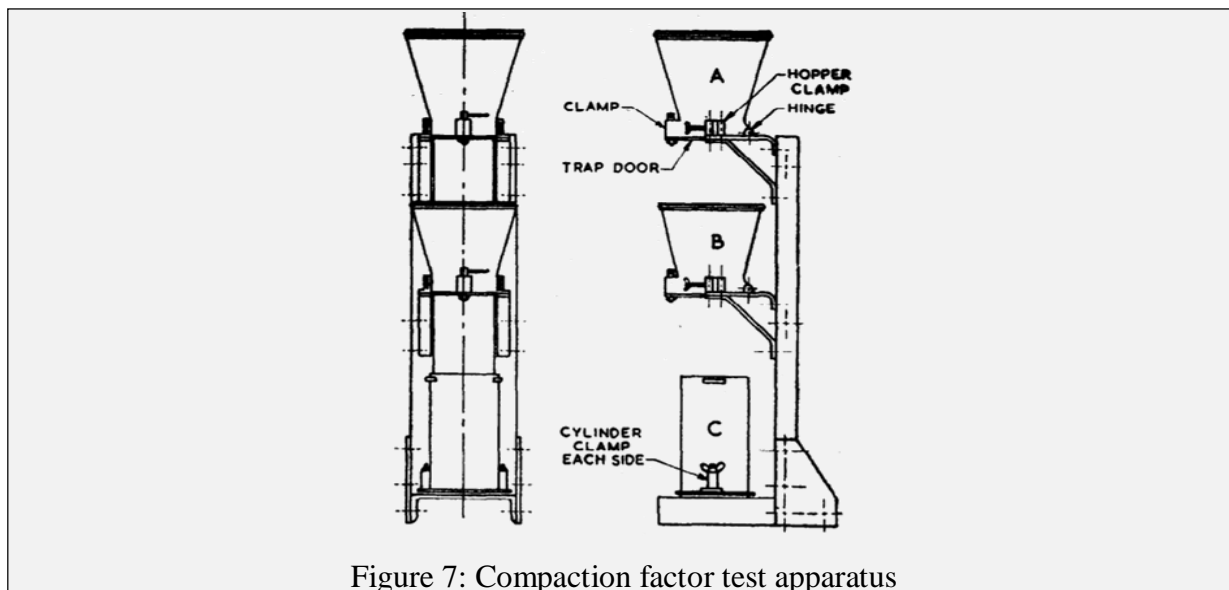

Objective: To measure the workability of concrete by compaction factor test.

Reference: IS: 1199-1959, SP: 23-1982.

Apparatus: Compaction Factor Apparatus, tamping rod, metallic sheet, weighing machine and scale.

Material: Cement, sand, coarse aggregate and water

Procedure:

1. Prepare a concrete mix for testing workability. Consider a W/C ratio of 0.5 to 0.6 and design mix of proportion about 1:2:4 (it is presumed that a mix is designed already for the test). Weigh the quantity of cement, sand, aggregate and water correctly. Mix thoroughly. Use this freshly prepared concrete for the test.
2. Place the concrete into the upper hopper up to its brim.
3. Open the trapdoor of the upper hopper. The concrete will fall into the lower hopper.
4. Open the trapdoor of the lower hopper, so that concrete falls into the cylinder below.
5. Remove the excess concrete above the level of the top of the cylinder; clean the outside of the cylinder.
6. Weigh the concrete in the cylinder. This weight of concrete is the "weight of partially compacted concrete", (W_1).
7. Empty the cylinder and refill with concrete in layers, compacting each layer well (or the same may be vibrated for full compaction). Top surface may be struck off level.

8. Find out weight of the concrete in the fully compacted state. This weight is the "Weight of fully compacted concrete" (W_2).

Observations:

- Weight of partially compacted concrete (W_1) : _____ Kg
- Weight of fully compacted concrete (W_2) : _____ Kg
- Compaction factor (F) = WW_1/WW_2 : _____.

Result:

The compaction factor of concrete is: _____.

Conclusions:

The compaction factor value indicates that the concrete has Low/ Medium/ High Degree of workability.

Precautions: (Discuss about the precautions to be taken while conducting this experiment)

-
-
-
-

Questions:

1. What is the difference between fully compacted and partially compacted concrete?
2. What is the significance of compacted concrete?
3. Define density of concrete & how it affects the strength of concrete?

EXPERIMENT NO. 13

TESTS FOR DETERMINATION OF COMPRESSIVE STRENGTH OF CONCRETE

Theory:

One of the important properties of concrete is its strength in compression. The strength in compression has a definite relationship with all other properties of concrete i.e. these properties improved with the improvement in compressive strength. Thus, with this single test one judge that whether Concreting has been done properly or not. In India cubical moulds of size $15\text{ cm} \times 15\text{ cm} \times 15\text{ cm}$ are commonly used.

The concrete is prepared with definite proportion is poured in the mould and tempered properly so as not to have any voids. After 24 hours these moulds are removed and test specimens are put in water for curing. The top surface of this specimen should be made even and smooth. This is done by putting cement paste and spreading smoothly on whole area of specimen. These specimens are tested by compression testing machine after 3, 7 or 28 days curing. Load should be applied gradually at the rate of 14 N/mm^2 per minute till the Specimens fails. Load at the failure divided by area of specimen gives the compressive strength of concrete. At least three specimens are tested at each selected age. The failure of the specimen is called as 'hour glass' type failure. This happens due to lateral restraint provided by the plates to the cubes.

Practically, the compression testing system develops a complex system of stresses due to end restraints provided by steel platens of compression testing machine (CTM). Under compression loading, due to "poisons effect", the cube specimen also undergo lateral expansion. However, the steel platens don't undergo lateral expansion to the same extent that of concrete. Thus, there exist a differential tendency of lateral expansion between steel platens and concrete cube faces. As a result of this, tangential forces are induced between the end surfaces of the concrete specimen and the adjacent steel platens of CTM. Therefore, in addition to the applied compressive stress; lateral shearing stresses are also effective in these specimens. Effect of this shear decreases to words the centre of the cube. Thus, the cube has near vertical crack at cubes centre and sometimes, the cube may completely disintegrate leaving a relatively undamaged central core. Figure 8 shows, typical failure patterns of the concrete cube.

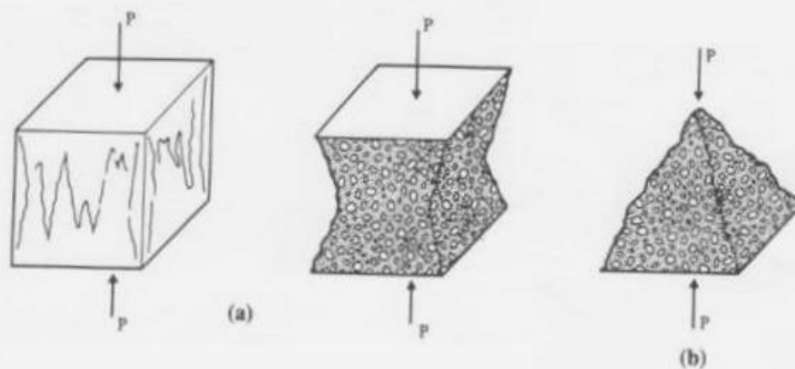

Figure 8 : Failure patterns of concrete cubes

Objective: To determine the cube strength of the concrete of given properties.

Reference: IS: 516 - 1959, IS: 1199-1959, SP: 23-1982, IS: 10086-1982.

Apparatus: Moulds for the test cubes, tamping rod, metallic sheet, Compressive testing machine.

Material: Cement, sand, aggregate and water, grease

Procedure:

1. Calculate the material required for preparing the concrete of given proportions
2. Mix them thoroughly in mechanical mixer until uniform colour of concrete is obtained
3. Pour concrete in the lightly greased cube moulds.
4. Fill concrete in two layers each of approximately 75 mm and ramming each layer with 35 blows evenly distributed over the surface of layer.
5. Struck off concrete flush with the top of the moulds.
6. Level the concrete at the top of the mould by means of trowel and give proper identification mark of the specimen.
7. Immediately after being made, they should be covered with wet mats.
8. Specimens are removed from the moulds after 24hrs and cured in water. Keep it for curing up to 28 days.

Testing of concrete cubes:

9. Take the cube out of water at the end of three days with dry cloth. Measure the dimensions of the surface in which the load is to be applied. Let be 'L' and 'B' respectively.
10. Place the cube in compressive testing machine and apply the load uniformly at the rate of 35N/mm².
11. Note the load at which the cube fails. Let it be 'P'. Also note the type of failure and appearance cracks
12. Calculate the compressive strength of the cube by using formula P/A . Where A is the area of loaded surface (i.e. $L \times B$).
13. Repeat the same procedure (steps 9 to 12) for other two cubes.
14. Repeat the whole procedure (Step 9 to 13) to find the compressive strength of the cube at the end of 7 days and 28 days.

Observation

(a) For 3 days strength:

Sl. No.	Length (in mm)	Breadth (in mm)	Load (in N)	compressive strength in N/mm ²	Remark
1					
2					
3					

Average =

(b) For 7 days strength:

Sl. No.	Length (in mm)	Breadth (in mm)	Load (in N)	compressive strength in N/mm ²	Remark
1					
2					
3					

Average =

(c) For 28 days strength:

Sl. No.	Length (in mm)	Breadth (in mm)	Load (in N)	compressive strength in N/mm ²	Remark
1					
2					
3					

Average =

Results:

The type and grade of concrete :

The compressive strength of cement at the end of

- i) 3 days : _____ . N/mm².
- ii) 7 days : _____ . N/mm².
- iii) 28 days : _____ . N/mm².

Precautions: (Discuss about the precautions to be taken while conducting this experiment)

-
-
-
-

Questions:

1. What is the effect of W/C ratio on compressive strength of concrete?
2. Mention the factors those affect the compressive strength of concrete?
3. What is butting of concrete mixture? Why is it done?
4. How does strength correlate with other properties of hardened concrete?

EXPERIMENT NO. 14

TESTS FOR DETERMINATION OF FLEXURAL STRENGTH OF CONCRETE

Theory:

Flexural strength is one measure of the tensile strength of concrete. It is a measure of an unreinforced concrete beam to resist failure in bending. It is measured by loading 150 x 150 mm concrete beams with a span length of 700 mm. This test is performed by three point loading experiment. The Third point loading test applies the forces at the 1/3 and 2/3 points equally from the top side by distributing a single centred force through a steel beam to two points rather than one. The beam is supported at two points from below near the ends. The bending moment is lower in a third point test than in a centre point test. Highway designer use a theory based on flexural strength for design of pavements. However, there is very limited use of flexural testing for structural concrete. Figure 9 shows a typical test arrangement for flexural strength test.

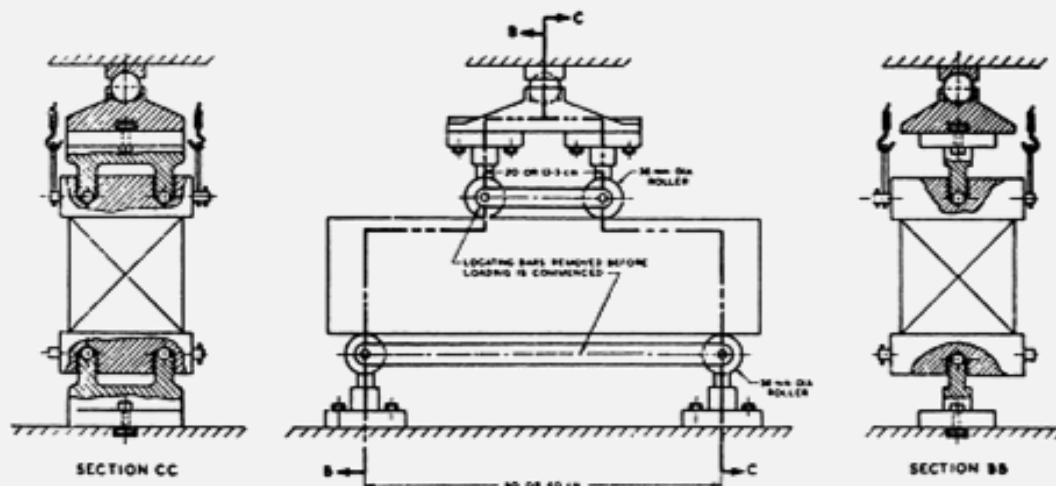

Figure 9: Arrangement for loading of flexure test specimen

Flexural strength tests are extremely sensitive to specimen preparation, handling, and curing procedure. Beams are very heavy and can be damaged when handled and transported from the jobsite to the lab. Allowing a beam to dry will yield lower strengths. The beams must be cured in a standard manner, and should be tested while wet. Meeting all these requirements on a job site is extremely difficult and hence often results in unreliable and generally low MR values. A short period of drying can produce a sharp drop in flexural strength.

Objective: To determine flexural strength of cubic concrete specimens.

Reference: IS: 516 - 1959, IS: 1199-1959, SP: 23-1982, IS: 10086-1982.

Apparatus: Flexural testing beam moulds, tamping rod, metallic sheet, universal testing machine.

Material: Cement, sand, aggregate and water, grease

Procedure:

1. Sampling of Materials: Samples of aggregates for each batch of concrete shall be of the desired grading and shall be in an air-dried condition. The cement samples, on arrival at the laboratory, shall be thoroughly mixed dry either by hand or in a suitable mixer in such a manner as to ensure the greatest possible blending and uniformity in the material.
2. Proportioning: The proportions of the materials, including water, in concrete mixes used for determining the suitability of the materials available, shall be similar in all respects to those to be employed in the work.
3. Weighing: The quantities of cement, each size of aggregate, and water for each batch shall be determined by weight, to an accuracy of 0.1 percent of the total weight of the batch.
4. Mixing of Concrete: The concrete shall be mixed by hand, or preferably, in a laboratory batch mixer, in such a manner as to avoid loss of water or other materials. Each batch of concrete shall be of such a size as to leave about 10 percent excess after moulding the desired number of test specimens.
5. Mould: The standard size shall be 15 × 15 × 70 cm. Alternatively, if the largest nominal size of the aggregate does not exceed 19 mm, specimens 10 × 10 × 50 cm may be used.
6. Compacting: The test specimens shall be made as soon as practicable after mixing, and in such a way as to produce full compaction of the concrete with neither segregation nor excessive laitance.
7. Curing: The test specimens shall be stored in a place, free from vibration, in moist air of at least 90 percent relative humidity and at a temperature of $27^{\circ} \pm 2^{\circ}\text{C}$ for 24 hours $\pm \frac{1}{2}$ hour from the time of addition of water to the dry ingredients.
8. Placing the Specimen in the Testing Machine: The bearing surfaces of the supporting and loading rollers shall be wiped clean, and any loose sand or other material removed from the surfaces of the specimen where they are to make contact with the rollers
9. The specimen shall then be placed in the machine in such a manner that the load shall be applied to the uppermost surface as cast in the mould, along two lines spaced 20.0 or 13.3 cm apart.
10. The axis of the specimen shall be carefully aligned with the axis of the loading device. No packing shall be used between the bearing surfaces of the specimen and the rollers.

11. The load shall be applied without shock and increasing continuously at a rate such that the extreme fibre stress increases at approximately 7 kg/sq cm/min, that is, at a rate of loading of 400 kg/min for the 15.0 cm specimens and at a rate of 180 kg/min for the 10.0 cm specimens.
12. The load shall be increased until the specimen fails, and the maximum load applied to the specimen during the test shall be recorded. The appearance of the fractured faces of concrete and any unusual features in the type of failure shall be noted.

Observation

- Length of Specimen (l) : _____ mm
- Width of the specimen (b) : _____ mm
- Depth of the specimen (d) : _____ mm

Sl. No.	Age of specimen	Maximum load (P) in N	Position of Fracture (a) in mm*	Modulus of rupture (f_b)** (MPa)
	7 days			
	28 days			

* ' a ' equals the distance between the line of fracture and the nearer support, measured on the centre line of the tensile side of the specimen.

** When $a > 200$ mm for a 150 mm specimen, the flexural strength of the specimen expressed as the modulus of rupture, f_b , is calculated from:

$$f_b = \frac{PP \times ll}{aa \times dd^2}$$

But, if $200 > a > 170$ mm for a 150 mm specimen f_b , is calculated from:

$$f_b = \frac{PP \times ll}{bb \times dd^2}$$

Results:

- The average 7 days modulus of rupture of concrete sample is :_____MPa
- The average 28 days modulus of rupture of concrete sample is :_____MPa

Precautions: (Discuss about the precautions to be taken while conducting this experiment)

-
-
-
-

Questions:

1. What is the relationship of flexural strength of concrete with its compressive strength?
2. What is the significance of moment of inertia with respect to bending stress?
3. What is cracking load?

EXPERIMENT NO. 15

TESTS FOR DETERMINATION OF SPLITTING TENSILE STRENGTH OF CONCRETE

Theory:

Splitting tensile strength is generally greater than the direct tensile strength and lower than the flexural strength (modulus of rupture). Splitting tensile strength is used in the design of structural light weight concrete members to evaluate the shear resistance provided by concrete and to determine the development length of the reinforcement.

This test method consists of applying a diametrical force along the length of a cylindrical concrete at a rate that is within a prescribed range until failure. This loading induces tensile stresses on the plane containing the applied load and relatively high compressive stresses in the area immediately around the applied load. Although we are applying a compressive load but due to Poisson's effect, tension is produced and the specimen fails in tension. Tensile failure occurs rather than compressive failure because the areas of load application are in a state of triaxial compression, thereby allowing them to withstand much higher compressive stresses than would be indicated by a uniaxial compressive strength test result. Thin, bearing strips are used to distribute the load applied along the length of the cylinder. The maximum load sustained by the specimen is divided by appropriate geometrical factors to obtain the splitting tensile strength.

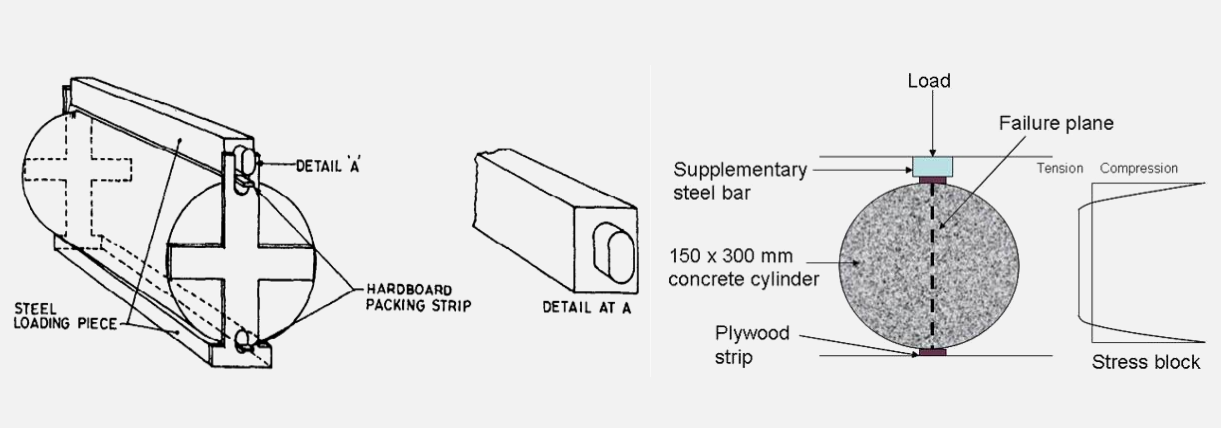

Figure 10: Arrangement for loading of splitting tensile test specimen

Objective: To determine splitting tensile strength of cylindrical concrete specimens.

Reference: IS: 5816 - 1999, IS: 1199-1959, SP: 23-1982, IS: 10086-1982.

Apparatus: Cylindrical mould conforming to IS: 10086-1982 for splitting tensile strength, tamping rod, metallic sheet, universal testing machine.

Material: Cement, sand, aggregate and water, grease

Procedure:

1. Sampling of Materials: Samples of aggregates for each batch of concrete shall be of the desired grading and shall be in an air-dried condition. The cement samples, on arrival at the laboratory, shall be thoroughly mixed dry either by hand or in a suitable mixer in such a manner as to ensure the greatest possible blending and uniformity in the material.
2. Proportioning : The proportions of the materials, including water, in concrete mixes used for determining the suitability of the materials available, shall be similar in all respects to those to be employed in the work
3. Weighing: The quantities of cement, each size of aggregate, and water for each batch shall be determined by weight, to an accuracy of 0.1 percent of the total weight of the batch.
4. Mixing of concrete: The concrete shall be mixed by hand, or preferably, in a laboratory batch mixer, in such a manner as to avoid loss of water or other materials. Each batch of concrete shall be of such a size as to leave about 10 percent excess after moulding the desired number of test specimens.
5. Mould: The cylindrical mould shall be of 150 mm diameter and 300 mm height conforming to IS: 10086-1982.
6. Compacting: The test specimens shall be made as soon as practicable after mixing, and in such a way as to produce full compaction of the concrete with neither segregation nor excessive laitance.
7. Curing: The test specimens shall be stored in a place, free from vibration, in moist air of at least 90 percent relative humidity and at a temperature of $27^{\circ} \pm 2^{\circ}\text{C}$ for 24 hours $\pm \frac{1}{2}$ hour from the time of addition of water to the dry ingredients.
8. Placing the specimen in the testing machine: The bearing surfaces of the supporting and loading rollers shall be wiped clean, and any loose sand or other material removed from the surfaces of the specimen where they are to make contact with the rollers.
9. Two bearing strips of nominal (1/8 in *i.e* 3.175mm) thick plywood, free of imperfections, approximately (25mm) wide, and of length equal to or slightly longer than that of the specimen should be provided for each specimen.
10. The bearing strips are placed between the specimen and both upper and lower bearing blocks of the testing machine or between the specimen and the supplemental bars or plates.
11. Draw diametric lines at each end of the specimen using a suitable device that will ensure that they are in the same axial plane. Center one of the plywood strips along the centre of the lower bearing block.
12. Place the specimen on the plywood strip and align so that the lines marked on the ends of the specimen are vertical and centred over the plywood strip.

13. Place a second plywood strip lengthwise on the cylinder, centred on the lines marked on the ends of the cylinder. Apply the load continuously and without shock, at a constant rate within, the range of 689 to 1380 kPa/min splitting tensile stress until failure of the specimen
14. Record the maximum applied load indicated by the testing machine at failure. Note the type of failure and appearance of fracture.

Observation

- Length of Specimen (l) : _____ mm
- diameter of the specimen (d) : _____ mm

Sl. No.	Age of specimen	Maximum load (P) in N	Spitting tensile strength in MPa ($TT = 2PP/\pi\pi ldd$)	Average spitting tensile strength (MPa)
	7 days			
	28 days			

Results:

- The average 7 days tensile strength of concrete sample is : _____ MPa
- The average 28 days tensile strength of concrete sample is : _____ MPa

Precautions: (Discuss about the precautions to be taken while conducting this experiment)

-
-
-
-

Questions:

1. What is the relationship of splitting tensile strength of concrete with its compressive strength?
2. What is the significance of splitting tensile test experiment?

EXPERIMENT NO. 16

TESTS ON BRICKS

Theory:

Brick is a very common construction material obtained by moulding clay in rectangular blocks of uniform size and then by drying and burning them at a required temperature. Due to high strength and durability, easy availability and low cost; they are nowadays widely used for building construction.

On the basis of their size, IS 1077:1992 classifies bricks into two categories, *i.e.* modular and non-modular type. The sizes of modular brick are selected in conformity with the metric system considering 100 mm module as the basis of all dimensional standardization. The standard modular sizes of Indian bricks are:

Without mortar	:	190 mm × 90 mm × 90 mm
With mortar	:	200 mm × 100 mm × 100 mm

However, bricks of non-modular sizes are also available in India, which satisfies other requirements of the code, but not the requirements regarding dimension. The standard sizes of non-modular bricks varies region to region basis. In Odisha the standard size of non-modular bricks available is 225 mm × 125 mm × 75 mm (without mortar). This size may vary slightly due to drying shrinkage.

To assess the size of the brick, at least twenty numbers of whole bricks is taken at random from the stock. All blisters, loose particles of clay and small projections shall be removed. Then they shall be arranged upon a level surface successively as shown in Figure 10 in contact with each other and in a straight line. The overall length of the assembled bricks shall be measured with a steel tape or other suitable inextensible measure sufficiently long to measure the whole row at one stretch. Measurement by repeated application of short rule or measure shall not be permitted. For a good quality of brick, tolerances in dimensions are allowed within $\pm 3.0\%$.

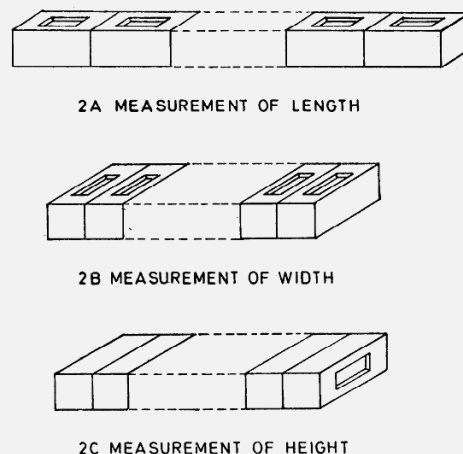

Figure 10: measurement of size of the brick

Bricks used in construction work should have adequate compressive strength to resist lateral and vertical loads. Ordinary bricks are designated on the basis of average compressive strength as follows:

Designation of bricks on the basis of compressive strength

Class	35	30	25	20	17.5	15	12.5	10	7.5	5
Average compressive strength (N/mm ²)	35	30	25	20	17.5	15	12.5	10	7.5	5

The compressive strength of any individual brick tested shall not fall below the minimum compressive strength specified for the corresponding class of brick. To access the compressive strength of the bricks, load is applied over the flat side keeping mortar filled face facing upwards.

Water absorption of a brick is defined as the ratio of weight of water absorbed to the dry weight of the unit under a given method of treatment in a standard period of time. Water absorption indicates degree of porosity in a brick. Strength, stiffness, unit weight and other properties decrease with porosity. For good quality of bricks, after immersion in cold water for 24 hours, the water absorption should not be more than 20% by weight

Efflorescence of bricks is usually seen as a white powder (salts of crystallization) caused by water soluble salts as Sulphates of Calcium, Magnesium, Sodium, Potassium etc. and Sodium Chloride. These salts are deposited on the surface of the bricks on the evaporation of water. Efflorescence decreases strength and stiffness of bricks. The liability to efflorescence is reported as '*nil*', '*slight*', '*moderate*', '*heavy*' or '*serious*' in accordance with the following definitions:

Ratings of efflorescence

Efflorescence	Definitions
Nil	No perceptible deposit of efflorescence
Slight	More than ten percent of the exposed area of the brick is covered with thin deposit of salts.
Moderate	Heavier deposit than under "slight" and covering up to fifty percent of exposed area of the brick surface but unaccompanied by powdering or flaking of the surface.
Heavy	Heavy deposit of salt covering more than fifty percent or more of the exposed area of the brick surface but unaccompanied by powdering or flaking of the surface.
Serious	Heavy deposit of salt accompanied by powdering or flaking of the exposed surface.

For good quality of bricks, the rating of efflorescence should not be more than '*slight*'.

Objective: To estimate dimension, tolerance, compressive strength, water absorption, and efflorescence of bricks.

Reference: IS 3495 (Part-1 to 4):1992.

Apparatus:

- (1) Dimensions and tolerance: Measuring tape, trowel and brush.
- (2) Water absorption: Weighing balance, metal tray about 5 cm deep, ovens.
- (3) Compressive strength: Compression testing machine
- (4) Efflorescence: A shallow flat bottom dish or tray.

Material:

- (1) Dimensions and tolerance: Bricks (20 nos.)
- (1) Water absorption: Bricks and water.
- (2) Compressive strength: Bricks, cement, sand, water and two 3 mm thick plywood sheets.
- (3) Efflorescence: Bricks and water.

Procedure:

For dimension and tolerance test:

1. Collect at least twenty numbers of whole bricks at random from the stock.
2. Remove all blisters, loose particles of clay and small projections from the surface of the brick.
3. Arrange the bricks upon a level surface successively as shown in Figure 1 in contact with each other and in a straight line.
4. Measure the overall length of the assembled bricks with the steel tape. Measurement by repeated application of short rule or measure shall not be permitted. If, for any reason it is found impracticable to measure bricks in one row, then divide the samples into rows of 10 bricks each and measure them separately to the nearest millimetre. Then, add all these dimensions together.

For water absorption test:

5. Dry the specimen in a ventilated oven at a temperature of 105 to 115° C for 24 hours. Then cool it to the room temperature and determine its weight (W1).
6. Immerse the dried specimen completely in clean water at a temperature of 27 ±2 ° C for 24 hours. Then remove the specimen, wiped of any traces of water and measure its weight (W2). This weighing shall be completed within three minutes after the specimen has been removed from water. Determine percentage of water absorption.

For compressive strength test:

7. Remove the unevenness observed in the bed faces to provide two smooth and parallel faces by grinding. Immerse in water at room temperature for 24 hours. Remove the specimen and drain out any surplus moisture at room temperature.
8. Fill the frog and all voids in the bed face flush with cement mortar having cement sand ratio 1:3.
9. Store under damp gunny bags for 24 hours followed by immersion in water for 3 days. Remove the bricks and wipe out traces of moisture.
10. Place the specimen with mortar filled face upward, between two 3 mm thick plywood sheets, carefully centred between platens of the testing machine. Apply load axially at a uniform rate of 14 N/mm²/min and note the maximum load at failure. Find compressive stress after dividing total load (in N) by loaded surface area (mm²)

For efflorescence test:

11. Place the end of the brick in the dish or tray. The depth of immersion in water shall be 25 mm.
12. Keep the whole arrangement at a temperature 20oC to 30oC until all the water in the dish is absorbed by the specimens and the surplus water evaporates.
13. When the water has been evaporated and the bricks appear to be dry, place a similar quantity of water in the dish and allow it to dry evaporate as before.
14. Examine the bricks for efflorescence after the second evaporation and report the results as the definition given in Table 3.

Observations:

Table 1: Observations on dimension and tolerance

Nos. of bricks tested : _____

Standard sizes of bricks taken: _____ mm × _____ mm × _____ mm.

	Length (mm)	Width (mm)	Thickness (mm)
For 20 nos. of bricks			
For One bricks			
Tolerance (in %)			

Table 2: Observations on compressive strength test

Sl. No.	Length (mm)	Width (mm)	Area (mm²)	Failure load (N)	Compressive strength (N/mm²)

Table 3: Observations on water absorption

Sl. No.	Dry weight of brick in kg (W₁)	Immersed weight of brick in kg (W₂)	%age of water absorption $\frac{WW_{22}-WW_{11}}{WW_{11}} \times 111111.$

Table 4: Observations on efflorescence test

The percentage of area where efflorescence occurred is : _____%. Thus the degree of efflorescence is _____.

Note: Carefully observe the brick that have undergone efflorescence test. And estimate the percentage of efflorescence area.

Result:

- The dimensions of given bricks are : _____mm × _____mm × _____mm
- Compressive strength for the brick specimen is : _____N/mm²
- Percentage of water absorption for the brick specimen is : _____% by weight.
- Degree of efflorescence for the brick specimen is found : _____

Conclusions:

- The given bricks has dimensions _____mm × _____mm × _____mm and the tolerances in dimensions are bellow/ above 3.0%. Thus the bricks are of good quality/ are not of good quality.
- The lowest compressive strength observed by the bricks specimen is _____ N/mm². Thus, the brick belongs to _____class.
- The percentage of water absorption for the brick specimen is less than/ more than 20% by weight. Thus, bricks are of good quality/ are not of good quality.
- The rating of efflorescence for the brick specimen is _____. This is acceptable/ not acceptable for good quality of bricks.

Precautions: (Discuss about the precautions to be taken while conducting this experiment)

-
-
-
-

Questions:

1. What are the characteristics of good bricks?
2. What is efflorescence in bricks? What are its causes and remedies?
3. What are the limits for water absorption and compressive strength for various classes of bricks?
4. Why frog filling is necessary for testing of compressive strength?
5. Describe various field tests performed to check the quality of bricks.

